



## MMF-300 Series/MDF-300 Addressable Monitor Modules

Section: Addressable Devices

### GENERAL

Four different monitor modules are available for Fire•Lite Alarm's MS-9200 and MS-9600 intelligent fire alarm control panels to suit a variety of applications. Monitor modules are used to supervise a circuit of dry-contact input devices, such as conventional heat detectors and pull stations, or monitor and power a circuit of two-wire smoke detectors (MMF-302).

**MMF-300 (Replaces M300)** — The MMF-300 Monitor Module is a standard-sized module (typically mounts to a 4" [101.6 mm] square box) that supervises either a Class A (Style D) or Class B (Style B) circuit of dry-contact input devices.

**MMF-301 (Replaces M301)** — The MMF-301 is a Miniature Monitor Module (a mere 1.3" (33.02 mm) H x 2.75" (69.85 mm) W x 0.5" (12.70 mm) D) used to supervise a Class B (Style B) circuit. Its compact design allows the MMF-301 to be mounted in a single-gang box behind the device it is monitoring.

**MMF-302 (Replaces M302)** — The MMF-302 Interface Module is a standard-sized module used to monitor and supervise compatible two-wire, 24 volt, smoke detectors on a Class A (Style D) or Class B (Style B) circuit.

**MDF-300 (New)** — The MDF-300 Dual Monitor Module is a standard-sized module (typically mounts to a 4" [101.6 mm] square box) that supervises two Class B (Style B) circuits of dry-contact input devices.

### MMF-300 MONITOR MODULE

- Built-in type identification automatically identifies this device as a monitor module to the control panel.
- Powered directly by two-wire SLC loop. No additional power required.
- High noise (EMF/RFI) immunity.
- SEMS screws with clamping plates for ease of wiring.
- Direct Decade 01 – 99 (MS-9200) and 01-159 (MS-9600) entry of address.
- LED flashes red during normal operation and latches on steady to indicate alarm.

The **MMF-300 Monitor Module** is intended for use in intelligent, two-wire systems, where the individual address of each module is selected using the built-in rotary switches. It provides either a two-wire or four-wire Class A or Class B fault-tolerant Initiating Device Circuit (IDC) for normally-open-contact fire alarm and supervisory devices. The MMF-300 can be used to replace M300 modules in existing systems.

**MMF-300 Applications** — Use to monitor a zone of four-wire smoke detectors, manual fire alarm pull stations, waterflow devices, or other normally-open dry-contact alarm activation devices. May also be used to monitor normally-open supervisory devices with special supervisory indication at the control panel. Monitored circuit may be wired as an NFPA Style B (Class B) or Style D (Class D) Initiating Device Circuit. A 47K ohm End-of-Line Resistor (provided) terminates the Style B circuit. No resistor is required for su-



7300-0075:185

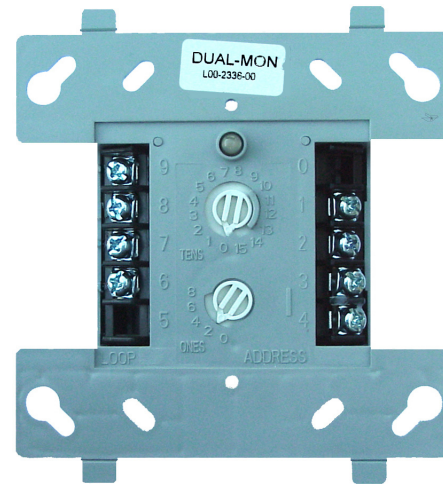

MDF-300

MDF300.jpg

pervision of the Style D circuit. Maximum IDC resistance is 1,500 ohms.

**MMF-300 Operation** — Each MMF-300 uses one of 99 (MS-9200) or 159 (MS-9600) available module addresses on an SLC loop. It responds to regular polls from the control panel and reports its type and the status (open/normal/short) of its Initiating Device Circuit (IDC). A flashing LED indicates that the module is in communication with the control panel. The LED latches steady on alarm (subject to current limitations on the loop).

### MMF-300 Specifications

**Nominal operating voltage:** 15 to 32 VDC.

**Maximum current draw:** 5.1 mA (LED on).

**Average operating current:** 400 µA (LED flashing).

**EOL resistance:** 47K ohms.

**Temperature range:** 32°F to 120°F (0°C to 49°C).

**Humidity range:** 10% to 93% noncondensing.

**Dimensions:** 4.5" (114.3 mm) high x 4" (101.6 mm) wide x 1.25" (31.75 mm) deep. Mounts to a 4" (101.6 mm) square x 2.125" (53.975 mm) deep box.

This document is not intended to be used for installation purposes. We try to keep our product information up-to-date and accurate. We cannot cover all specific applications or anticipate all requirements. All specifications are subject to change without notice. For more information, contact Fire•Lite Alarms, One Fire-Lite Place, Northford, Connecticut 06472. Phone: (800) 627-3473, Toll Free FAX: (877) 699-4105, FAX Back:(888) 388-3299.

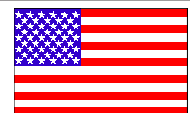

Made in the U.S.A.

## MMF-301 MINI MONITOR MODULE

- Built-in type identification automatically identifies this device as a monitor module to the MS-9200 or MS-9600.
- Powered directly by two-wire SLC Loop. No additional power required.
- High noise (EMF/RFI) immunity.
- Tinned, stripped leads for ease of wiring.
- Direct-dial entry of address (01-99 for MS-9200, 01-159 for MS-9600).

The **MMF-301 Mini Monitor Module** can be installed in a single-gang junction directly behind the monitored unit. Its small size and light weight allow it to be installed without rigid mounting. The MMF-301 is intended for use in intelligent, two-wire systems where the individual address of each module is selected using rotary switches. It provides a two-wire initiating device circuit for normally-open-contact fire alarm and security devices. The MMF-301 can be used to replace M301 module in existing systems.

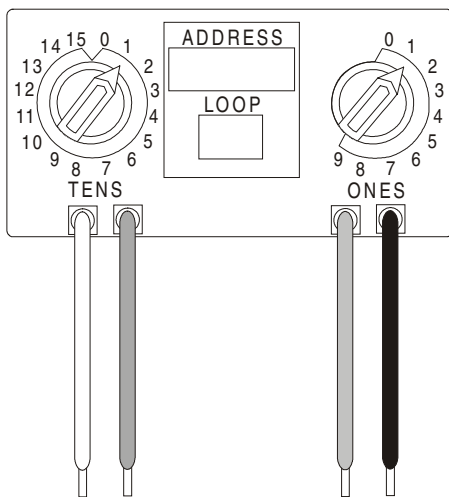

**MMF-301 Applications** — Use to monitor a single device or a zone of four-wire smoke detectors, manual fire alarm pull stations, waterflow devices, or other normally-open dry-contact devices. May also be used to monitor normally-open supervisory devices with special supervisory indication at the control panel. Monitored circuit/device is wired as an NFPA Style B (Class B) Initiating Device Circuit. A 47K ohm End-of-Line Resistor (provided) terminates the circuit.

**MMF-301 Operation** — Each MMF-301 uses one of 159 (MS-9600 only) available module addresses on an SLC loop. It responds to regular polls from the control panel and reports its type and the status (open/normal/short) of its Initiating Device Circuit (IDC).

### MMF-301 Specifications

- Nominal operating voltage:** 15 to 32 VDC.
- Average operating current:** 375  $\mu$ A maximum.
- EOL resistance:** 47K ohms.
- Temperature range:** 32°F to 120°F (0°C to 49°C).
- Humidity range:** 10% to 93% noncondensing.
- Dimensions:** 1.3" (33.02 mm) high x 2.75" (69.85 mm) wide x 0.5" (12.70 mm) deep.
- Wire length:** 6" (152.4 mm) minimum.

## MMF-302 INTERFACE MODULE

- Supports compatible two-wire smoke detectors.
- Supervises IDC wiring and connection of external power source (resettable).
- High noise (EMF/RFI) immunity.
- SEMS screws with clamping plates for ease of wiring.
- Direct-dial entry of address (01-99 for MS-9200, 01-159 for MS-9600).
- LED flashes during normal operation.
- LED latches steady to indicate alarm on command from control panel.

The **MMF-302 Interface Module** is intended for use in intelligent, addressable systems, where the individual address of each module is selected using built-in rotary switches. This module allows intelligent panels to interface and monitor two-wire conventional smoke detectors. It transmits the status (normal, open, or alarm) of one full zone of conventional detectors back to the control panel. All two-wire detectors being monitored must be UL compatible with the module.

**MMF-302 Applications** — Use the MMF-302 to monitor a zone of two-wire smoke detectors. The monitored circuit may be wired as an NFPA Style B (Class B) or Style D (Class A) Initiating Device Circuit. A 3.9 K ohm End-of-Line Resistor (provided) terminates the end of the Style B or D (class B or A) circuit (maximum IDC loop resistance is 25 ohms). Install ELR across terminals 8 and 9 for Style D application.

**MMF-302 Operation** — Each MMF-302 uses one of 159 (MS-9600 only) available module addresses on an SLC loop. It responds to regular polls from the control panel and reports its type and the status (open/normal/short) of its Initiating Device Circuit (IDC). A flashing LED indicates that the module is in communication with the control panel. The LED latches steady on alarm (subject to current limitations on the loop).

### MMF-302 Specifications

- Nominal operating voltage:** 15 to 32 VDC.
- Maximum current draw:** 5.1 mA (LED on).
- Average operating current:** 270  $\mu$ A (LED flashing).
- EOL resistance:** 3.9K ohms.
- External supply voltage (between Terminals T3 and T4):** **DC voltage:** 18 to 28 volts power limited. **Ripple voltage:** 0.1  $V_{RMS}$  maximum. **Current:** 90 mA per module maximum. Requires regulated, resettable 24 VDC power.
- Temperature range:** 32°F to 120°F (0°C to 49°C).
- Humidity range:** 10% to 93% noncondensing.
- Dimensions:** 4.5" (114.3 mm) high x 4" (101.6 mm) wide x 1.25" (31.75 mm) deep. Mounts to a 4" (101.6 mm) square x 2.125" (53.975 mm) deep box.

## MDF-300 DUAL MONITOR MODULE

- Built-in type identification automatically identifies this device as two monitor modules to the control panel.
- Powered directly by the two-wire SLC loop. No additional power required.
- High noise (EMF/RFI) immunity.
- SEMS screws with clamping plates for ease of wiring.
- Direct-dial entry of address 01 – 159 on the MS-9600.
- LED flashes red during normal operation and latches on steady red to indicate alarm.

The MDF-300 Dual Monitor Module is intended for use in intelligent, two-wire systems, where the individual address of each module is selected using the built-in rotary switches. It provides two independent two-wire fault-tolerant Initiating Device Circuits (IDCs) at two separate, consecutive addresses. It is capable of monitoring normally open-contact fire alarm and supervisory devices, or either normally open or normally closed devices for non-fire applications.

**MDF-300 Applications** - Use to monitor a zone of four-wire smoke detectors, manual fire alarm pull stations, waterflow devices, or other normally-open dry-contact alarm activation devices. May also be used to monitor normally-open supervisory devices with special supervisory indication at the control panel. Monitored circuit may be wired as an NFPA Style B (Class B) Initiating Device Circuit. The 47K ohm End-of-Line Resistors (provided) terminate the Style B circuit. Maximum IDC resistance is 1,500 ohms.

**MDF-300 Operation** - Each MDF-300 uses two of 99 (MS-9200) or 159 (MS-9600) available module addresses on an SLC loop. It responds to regular polls from the control panel and reports its type and the status (open/normal/short) of its Initiating Device Circuit (IDC). A flashing LED indicates that the module is in communication with the control panel. The LED latches steady on alarm (subject to current limitations on the loop).

### MDF-300 Specifications

**Nominal operating voltage:** 15 to 32 VDC.

**Maximum current draw:** 5.1 mA (LED on).

**Average operating current:** 750  $\mu$ A (LED flashing).

**EOL resistance:** 47K ohms.

**Maximum IDC wire resistance:** 1,500 Ohms.

**Temperature range:** 32°F to 120°F (0°C to 49°C).

**Humidity range:** 10% to 93% noncondensing.

**Dimensions:** 4.5" (114.3 mm) high x 4" (101.6 mm) wide x 1.25" (31.75 mm) deep. Mounts to a 4" (101.6 mm) square x 2.125" (53.975 mm) deep box.

**Accessories:** SMB500 electrical box.

### INSTALLATION

**MMF-300**, **MMF-302** and **MDF-300** modules mount directly to a standard 4" (101.6 mm) square, 2.125" (53.975 mm) deep, electrical box. They may also be mounted to the SMB500 surface-mount box. Mounting hardware and installation instructions are provided with each module. All wiring must conform to applicable local codes, ordinances, and regulations. These modules are intended for power-limited wiring only.

The **MMF-301** module is intended to be wired and mounted without rigid connections inside a standard electrical box. All wiring must conform to applicable local codes, ordinances and regulations.

## ARCHITECTS'/ENGINEERS' SPECIFICATIONS

Specifications of these and all Fire•Lite Alarms products are available from Fire•Lite Alarms.

### PRODUCT LINE INFORMATION

<b>MMF-300</b>	Monitor Module.
<b>MMF-301</b>	Mini Monitor Module.
<b>MMF-302</b>	Two-Wire Detector Monitor Module.
<b>MDF-300</b>	Dual Monitor Module.
<b>SMB500</b>	Optional Surface-Mount Backbox.

### MOUNTING DIAGRAM for standard-sized modules

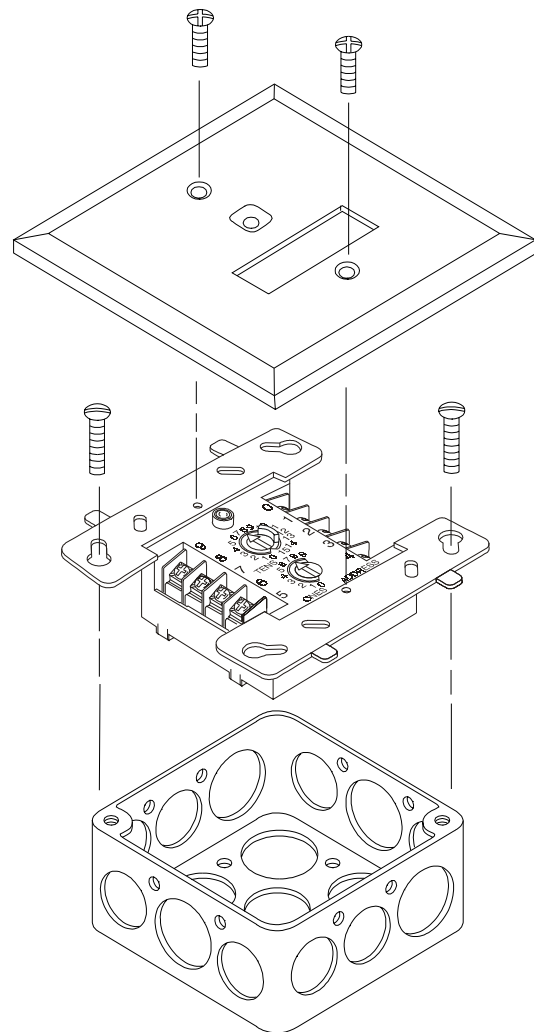

52121mt1.wmf