



30-2021-24 and 30-2021E-24 Ultraviolet Flame Detectors

Section: Conventional Initiating Devices

GENERAL

The **Pyrotector Model 30-2021-24** and **Model 30-2021E-24 Ultraviolet (UV) Flame Detectors** are highly sensitive to the ultraviolet radiation given off by all types of flames, including those produced by flammable liquids and gases. Since the detector does not respond to normal ambient light conditions such as sunlight, incandescent or fluorescent lighting, it is ideally suited for use as a flame detector in a variety of areas.

The Pyrotector Ultraviolet Flame Detector is a compact unitized package consisting of a detection tube, encapsulated solid state electronic circuitry, and a dry-contact Form-C (SPDT) alarm relay. In the event of an alarm, the relay latches on and an alarm light is illuminated for easy identification of the unit in the alarm state. The relay is reset by momentarily interrupting power to the unit. A three-second time delay is built in to minimize false alarms caused by the presence of sparks, lightning, etc.

- Model **30-2021-24** is contained in a **general purpose enclosure** and is intended for indoor use only. It mounts on a standard 4" (10.16 cm) octagonal electrical junction box (*not included*).
- Model **30-2021E-24** is intended for indoor use and is contained in an **explosion-proof enclosure** that meets all requirements for NEC Class I Groups C and D; Class II Groups E, F, and G; and Class III hazardous locations.
- Both models operate on 24 VDC.

THEORY OF OPERATION

The Model 30-2021-24 and Model 30-2021E-24 UV Flame Detectors operate with a Geiger-Muller-type tube that utilizes an ultraviolet sensitive photocathode within a fused silica envelope. When exposed to UV radiation, the photocathode emits electrons that ionize the inert gas inside the tube. This initiates the current flow that produces an alarm signal.

APPLICATION CONSIDERATIONS

To ensure proper operation of the detector, the viewing window and the surface of the sensing tube must be kept clean and free of contaminating films at all times. When cleaning the sensing tube, the user must exercise caution to apply minimum pressure, thereby minimizing the possibility of damage to the detector tube.

Cutting and welding operations within the cone of vision of the detector can generate high levels of UV radiation that can result in actuation of the detection system. To avoid unwanted alarms, it is suggested that the detection system be de-energized while these activities are occurring.

It should be noted that **ultraviolet detectors will not detect glowing embers**. A high-speed ember detector such as the Model **30-2054-24** or **30-2054A-24** should be used for this type of application.

SPECIFICATIONS

- **Operating voltage:** 22 to 27 VDC for 24 VDC unit.
- **Operating current:** **STANDBY:** 12 mA maximum @ 24 VDC. **ALARM:** 100 mA @ 24 VDC.

Pyrotector is a brand name of Detector Electronics Corporation.



California State Fire Marshal
7210-1208:102

Model 30-2021-24



Model 30-2021E

- **Alarm relay contact rating:** 1 A @ 26 VDC.
 - **Spectral sensitivity range:** 1700 to 2900 angstroms, with peak response at 2100 angstroms.
 - **Temperature range:** -13°F (-25°C) to +140°F (+65°C).
 - **Humidity range:** up to 90% RH.
- Physical Specifications, 30-2021-24:**
- **Enclosure type:** general-purpose painted steel with protective cage and totally encapsulated electronics.
 - **Dimensions:** 4.09" (10.389 cm) diameter; 3" (7.62 cm) deep.
 - **Weight:** 0.75 lb. (0.34 kg).

NOTIFIER® is an operation of **Honeywell**.

This document is not intended to be used for installation purposes. We try to keep our product information up-to-date and accurate. We cannot cover all specific applications or anticipate all requirements. All specifications are subject to change without notice. For more information, contact **NOTIFIER**. Phone: (203) 484-7161 FAX: (203) 484-7118



12 Clintonville Road, Northford, Connecticut 06472



Made in the U.S.A.

Physical Specifications, 30-2021E-24:

- **Enclosure type:** explosion-proof housing with 3/4" (1.905 cm) NPT female entries. **NEC Class I**, Groups C and D; **Class II**, Groups E, F, and G; **Class III**.
- **Dimensions:** 6.76" (17.17 cm) x 2.75" (6.985 cm) x 4.75" (12.065 cm).
- **Weight:** 3.75 lbs. (1.7 kg).

DETECTOR SENSITIVITY

The response time of the detector is a function of the size of the fire, fuel type, and the distance from the detector to the fire. Smaller fires and greater distances normally require greater response times. **Figure 1** illustrates the relative sensitivity of the Model 30-2021-24 Detector to gasoline fires. **Figure 2** shows the relative sensitivity of the Model 30-2021E-24.

The Model 30-2021E-24 is approximately 10% less sensitive. For example, a three-second response time is achieved at 10 feet (3.048 m) rather than 12 feet (3.658 m) when detecting a 6" (15.24 cm) gasoline fire.

CONE OF VISION

The Model 30-2021-24 has an 180° cone of vision. Relative sensitivity is greatest at a viewing angle of 45° on either side of the central axis. At angles greater than 45°, sensitivity decreases, as illustrated in **Figure 3**. For the viewing pattern of Model 30-2021E-24, with 60° cone of vision, see **Figure 4**.

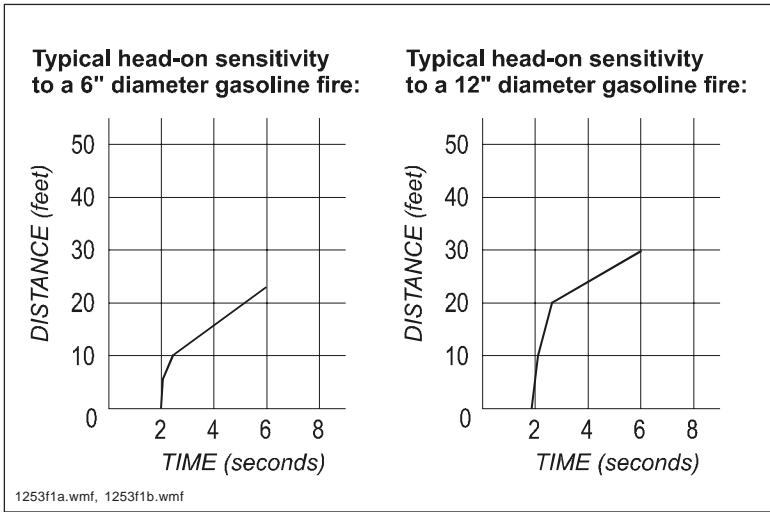

Figure 1: Model 30-2021-24 Detector Sensitivity

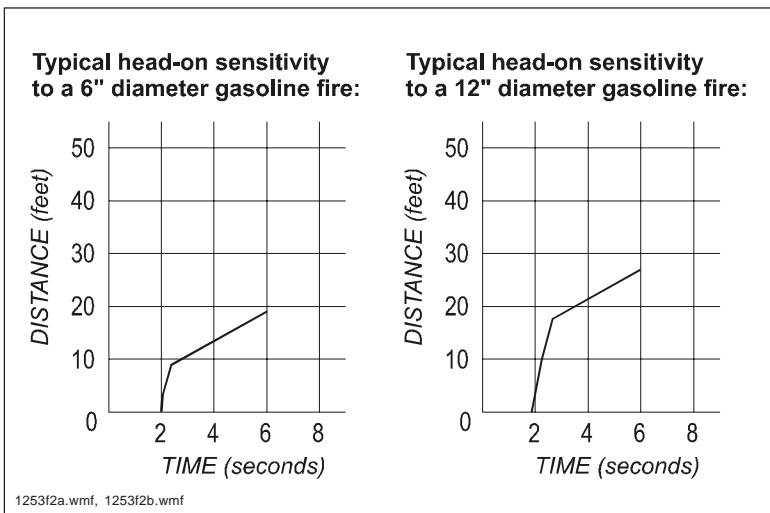
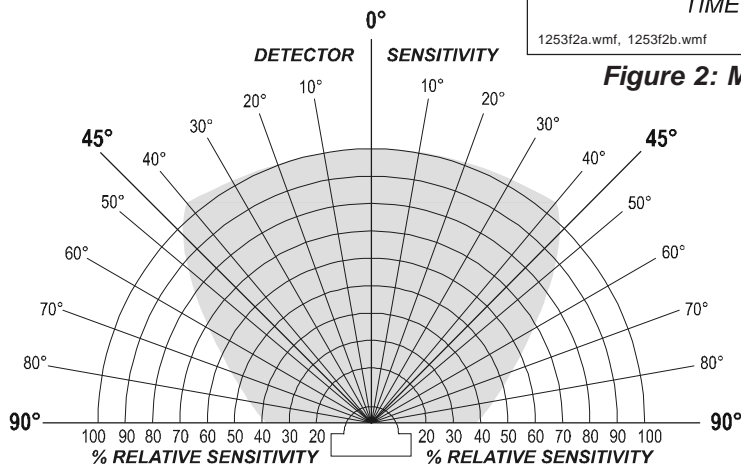
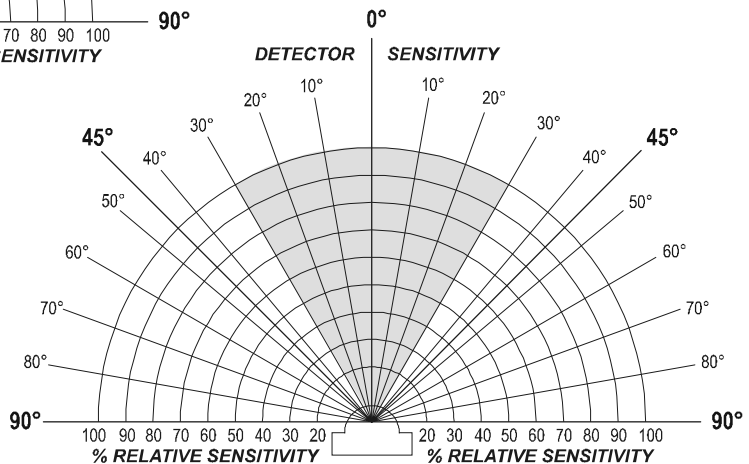

Figure 2: Model 30-2021E-24 Detector Sensitivity



**Figure 3 (above): Model 30-2021-24
Figure 4 (at right): Model 30-2021E-24
Viewing Patterns for Cone of Vision**



INSTALLATION AND WIRING

The Model 30-2021-24 and Model 30-2021E-24 are intended for use in indoor applications. Connection to both models is via color-coded wire leads with the following functions:

- **RED:** +24 V operating power input.
- **BLACK:** Common 24 V operating power input.
- **WHITE:** ALARM relay – common.
- **BLUE:** ALARM relay – normally closed contact.
- **ORANGE:** ALARM relay – normally open contact.

The Model 30-2021-24 can be mounted on a standard 4" (10.16 cm) junction box. The junction box should be mounted securely to a supporting surface such as a wall, piping, etc. See **Figure 5** for 30-2021-24 mounting hole locations. Connect the external wiring to the detector as illustrated in **Figures 7 and 8** (page 4).

To install the Model 30-2021E-24, remove the front cover from the detector and mount the detector on the junction box. See **Figure 6** for 30-2021E-24 mounting hole locations. Make the electrical connections as shown in **Figures 7 and 8** (page 4). Place the cover back on the detector and mount it to any flat surface.

A swivel mount is available for use with the Model 30-2021E to facilitate installation and orientation and provide easy adjustment for the viewing field of the detector — order part number **10-3995**. This optional accessory meets the same NEC requirements for use in hazardous areas as the detector.

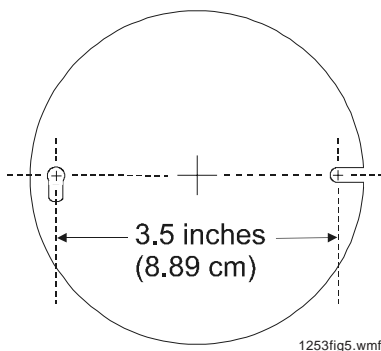

Figure 5: Model 30-2021-24 Mounting Holes

NOTE: Mounting hole diagrams **Figures 5 and 6** are not shown to scale with each other.

MAINTENANCE

To assure maximum detector sensitivity, keep the surface of the sensor tube free from dirt or other contaminants at all times. Periodically test the sensitivity of the detector using a controlled flame or a UV test lamp such as the model **W8066**.

ENGINEERING SPECIFICATIONS

The unit shall be an open area ultraviolet flame detector designed to operate on 24 VDC.

It shall have encapsulated electronic circuitry and Form-C alarm relay contacts. The unit shall have built-in alarm indication from the front of the detector. It shall respond to a 12-inch (30.48 cm) diameter gasoline fire in six seconds when viewed head-on from a distance of 30 feet (9.144 m). The detector shall not respond to normal ambient light conditions such as sunlight, incandescent, or fluorescent light.

The detector shall have a three-second time delay to spurious responses. Model 30-2021-24 shall have a 180° cone of vision with the greatest sensitivity at 45° on either side of the central axis. Model 30-2021E-24 shall have a 60° cone of vision.

Explosion-proof units shall meet NEC Class I, Groups C and D; Class II Groups E, F, and G; Class III.

Units shall be Factory Mutual approved.

PRODUCT LINE INFORMATION

- 30-2021-24** Ultraviolet flame detector, 24 VDC, in a general-purpose-type enclosure intended for indoor use.
- 30-2021E-24** Ultraviolet flame detector, 24 VDC, contained in an explosion-proof enclosure.
- 10-3995** Swivel mount for use with the 30-2021E-24.

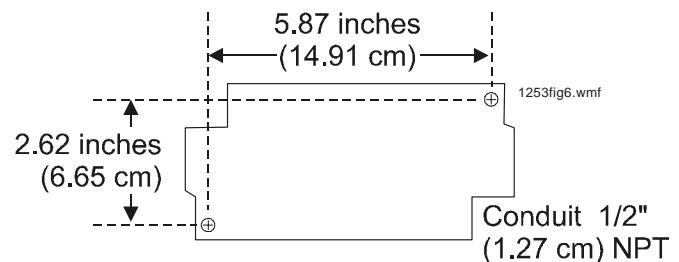

Figure 6: Model 30-2021E-24 Mounting Holes

WIRING DIAGRAMS

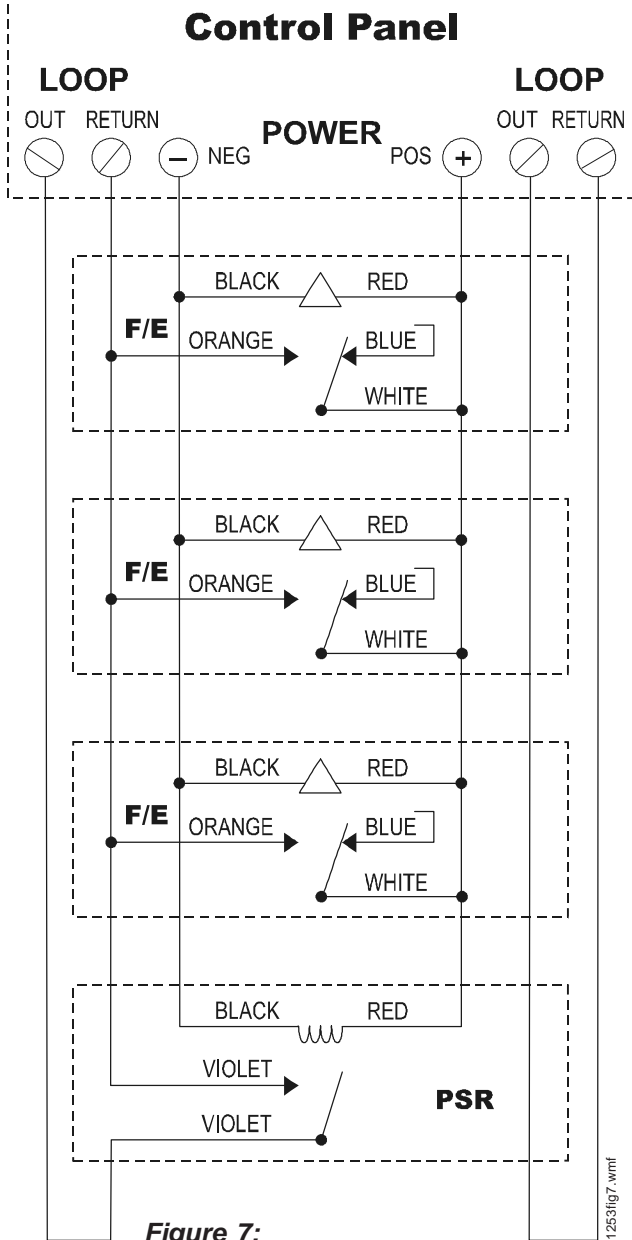

Figure 7:
Double-Loop Panel Wiring

KEY:

- **RED:** +24 V operating power input.
- **BLACK:** Common 24 V operating power input.
- **WHITE:** ALARM relay – common.
- **BLUE:** ALARM relay – normally closed contact.
- **ORANGE:** ALARM relay – normally open contact.
- **F/E:** Flame or ember detector.
- **PSR:** Power supervision relay P 2040 or equivalent.
- **EOL:** End-of-line device as required by panel.

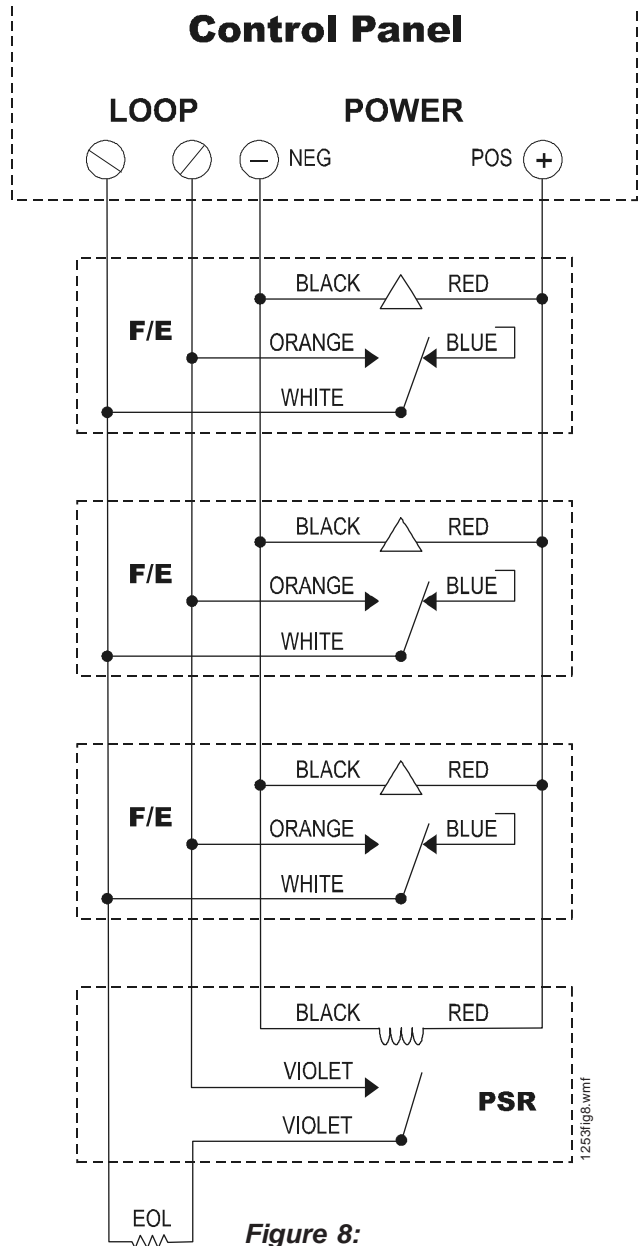

Figure 8:
Single-Loop Panel Wiring